

The Mobile PREDATOR Pump comes equipped with Western's own **1200 MIXER** The Plaster/Mortar mixer designed exclusively for the professional

We offer the widest selection of engines and mixer configurations with Mechanical drives, Hydraulic drives, and the exclusive **POWERDUMP** system).

The mixer has a Powder Coating Finish and hot dip galvanized engine cover for extreme corrosion resistance.



Wider round tubing dump handle for a better grip.

Water distribution rail (When water tank is used)

Tough 12-gauge swing away engine cover makes it the longest lasting.

Structural tubing forms the strongest frame available.

Durable steel drum with 1/4 inch thick sides.

- Steel or Rubber blades.
- FAST-MIX 6 paddle design.
- Weldable grade cast iron paddles.

Longest Lasting Paddle Shaft Seals

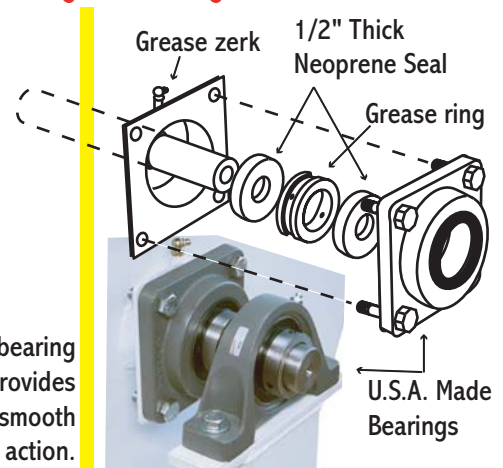

Double bearing pivot point provides an easy and smooth dumping action.

U.S.A. Made Bearings

Mechanical Drive

Gasoline & diesel engine options

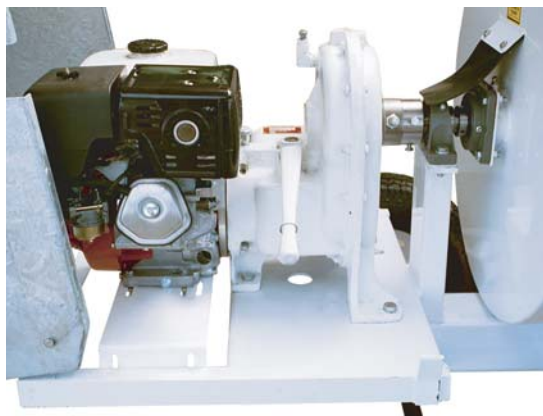

Totally enclosed transmission & clutch are immersed in oil for a long, trouble free life.

Solid base-mount transmission.

Hydraulic Drive

Gasoline & diesel engine options

Reversible drive for safe & quick release of jams.



With Diesel powered PREDATOR MOBILE pumps you have the option of powering the hydraulic drive with the pump engine.